



**BENTLEY**

HOME

Available At:

**PALAZZO COLLEZIONI**

[www.palazzocollezioni.com.au](http://www.palazzocollezioni.com.au)



**BENTLEY**

HOME

**EXTRAORDINARY JOURNEYS  
BEGIN FROM HOME**

# S I C I L Y



# INTRODUCTION



It is a joy to be writing this introduction to the Bentley Home 2021 Collection catalogue. Through these extraordinary images I feel as though I am there in Sicily, surrounded by the dramatic, rugged coastal landscapes, yet cocooned within the comfort of the most luxurious furniture pieces.

Sicily is a unique island and the ideal location for this presentation. It is beautiful, with a rich and unique cultural heritage, especially with regard to art, music, literature, architecture and cuisine. Clearly synonymous with the culture, heritage and iconic status of Bentley.

This collection is a true reflection of the close collaborative relationship between the design departments of Bentley Home and Bentley Motors. A relationship that builds on a century of unrivalled quality and craftsmanship from Bentley Motors while adding the unmistakable quality and style of Italian furniture design. The result is a product that is unique, sophisticated, luxurious, warm and modern.

For me, the beauty of this collaborative relationship is in the elegant and subtle translation of the brand DNA from automotive design to furniture design. The furniture pieces have the codes, the spirit and the soul of Bentley, but they are

far from being literal pastiches. Similarly, the photography and outdoor locations used here are a poetic metaphor for a road trip. The car is there – but only in your imagination.

The relationship between the design departments is also reciprocal. The furniture pieces benefit from the technical know-how and precision inherent in automotive design, where millimetres are crucial and everything is engineered and detailed to the highest level. And as the designing, manufacturing and releasing of furniture is far quicker and nimbler than it is for cars, things can be tried out in the furniture pieces that could prove to be beneficial later for the development of the cars.

It's exciting to think that there may be clues and tips in this furniture collection that may develop and resurface in the design of a future classic Bentley car.

This design language is of course always progressing and always evolving, and Home may reflect where Motors is going. It's certainly going in an exciting direction – exemplified perfectly in new visual communication and the creative concept of this catalogue.

The breath-taking photography illustrates the power of what nature can create and the power of what humans can achieve.



The visceral beauty of the sea and all the elements, contrasts perfectly with the serenity and the sophistication of the pieces. The furniture makes you feel as though you could sleep peacefully despite being surrounded by this raw, powerful, tumultuous landscape. It is the ultimate contrast, and great design is all about contrast. A storm rages but you are safe. Protected by this generous luxury. The ultimate luxury of space and comfort.

The mirrors used in the photographs are also such a clever touch. They add a modern, conceptual art vibe but are also practical in giving us a 360-degree view. The photographs

reveal all. You can see all the details and all the curves. And with curves like these – you don't want any to be hidden. You see many different angles and many different perspectives. Nothing is hidden. And it's an intervention. An intervention into nature. Our impact on nature – revealed in the most beautiful way. Design and nature in perfect harmony.

This harmony with the environment is crucial to Bentley. We are all now, more than ever, conscious of our impact on the planet and we must all do what we can to limit that impact. But we must still create beautiful things – it's what makes us unique as human beings. As the historian Simon

Schama said recently: 'We are the art-making animal'. If we stop this, it is a denial of our instincts and of what makes us civilised. We must be more intelligent, mindful and considerate in the way we make things in order to ensure that they are sustainable, but we must continue to make beautiful things. Fewer but better things.

It is reassuring to know that all the high-quality materials used – the fine leather, wood, metals and innovative new materials and finishes for which Bentley is renowned – are ethically sourced and stringently tested to ensure they meet the brand's quality and sustainability standards. And these pieces are designed to

last. For me, this is the very definition of sustainability. As the photographs suggest – these pieces are a friend of nature.

Bravo to all at Bentley for this brave new direction. This change of gear is daring and modern. Is it possibly a gamble? I don't think so. Too often, Luxury brands can tend to be too conservative, and they stand still. But a brand like Bentley cannot stand still. It must move, it must lead. We need brave new directions for our brave new world, and fortune favours the brave.

Tony Chambers

## CEFALÙ

- 014 Newent Armchair
- 022 Styal Desk
- 032 Ramsey Loveseat

## PUNTA BIANCA

- 046 Aldford Table
- 054 Ridley Chair
- 058 Havergate Night Collection
- 066 Ramsey Bed

## FAVIGNANA

- 080 Ramsey Sofa
- 086 Swan Sofa
- 094 Ramsey Armchair

## CUSTOMACI

- 106 Newent Bed
- 116 Newent Sofa
- 126 Eastwood Bookshelf

## 133 TECHNICAL

## 141 BACKSTAGE

# FROM MESSINA TO CEFALÙ



ART, HISTORY AND ARCHITECTURE ENTWINE IN CEFALÙ,  
A UNESCO WORLD HERITAGE SITE NEAR PALERMO WHERE  
ARAB-NORMAN LEFT THEIR MARK. FROM THE MEDIEVAL TOWN  
YOU CAN SEE THE OLD PORT, THROUGH A MAZE OF STREETS  
THAT LEAD DOWN TO THE SEA.





NEWENT ARMCHAIR







NEWENT ARMCHAIR



STYAL DESK





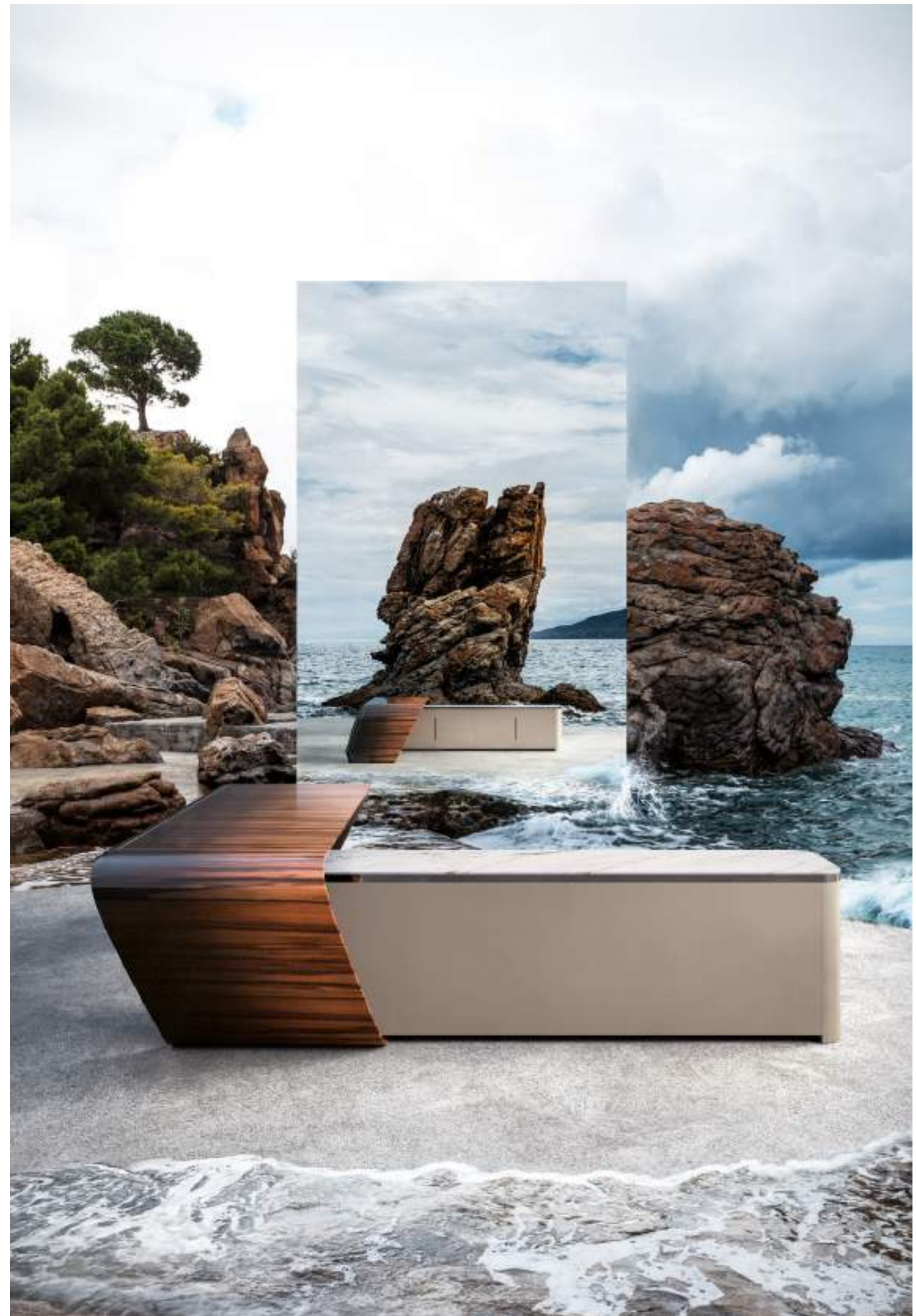





STYAL DESK



RAMSEY LOVESEAT

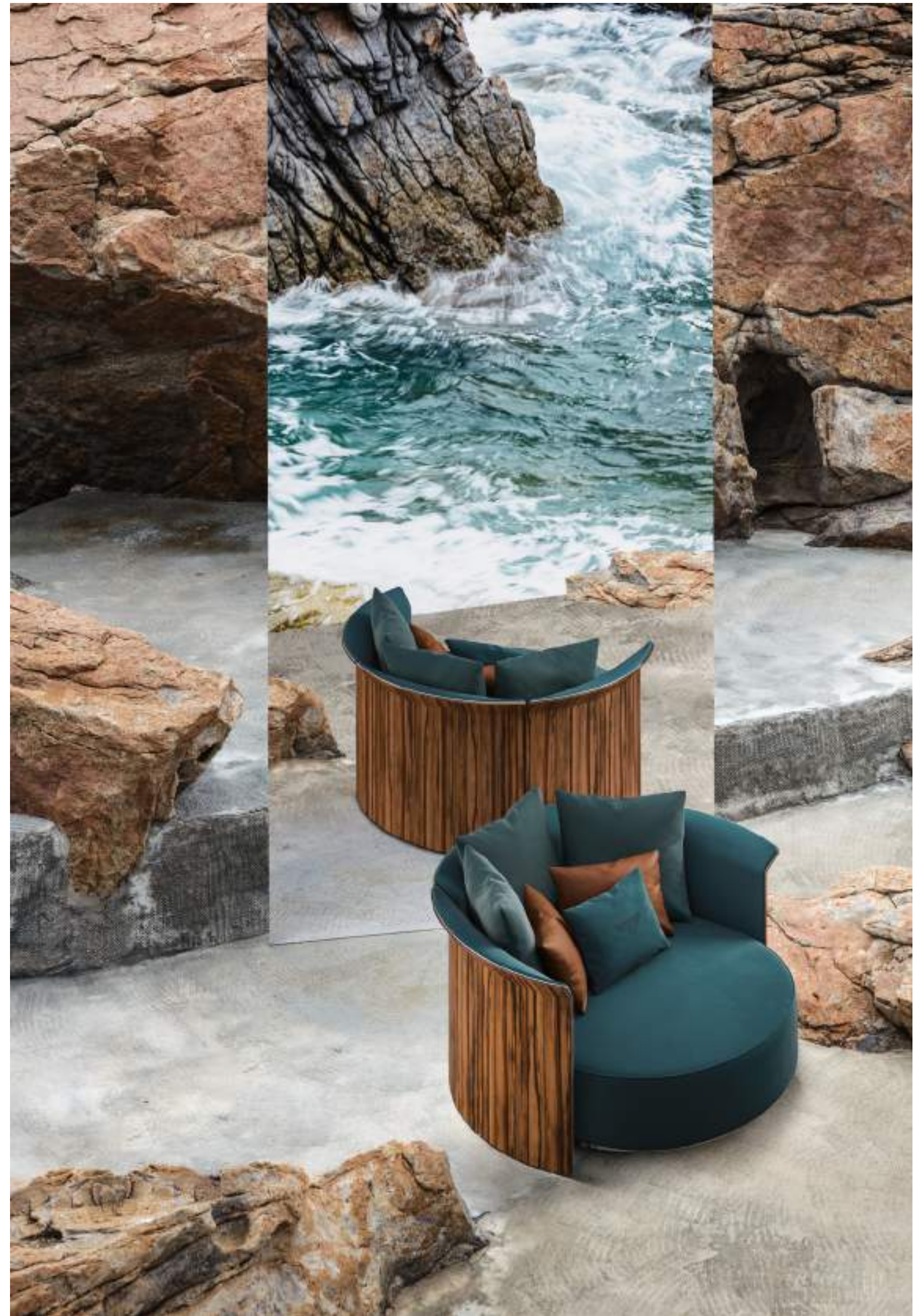



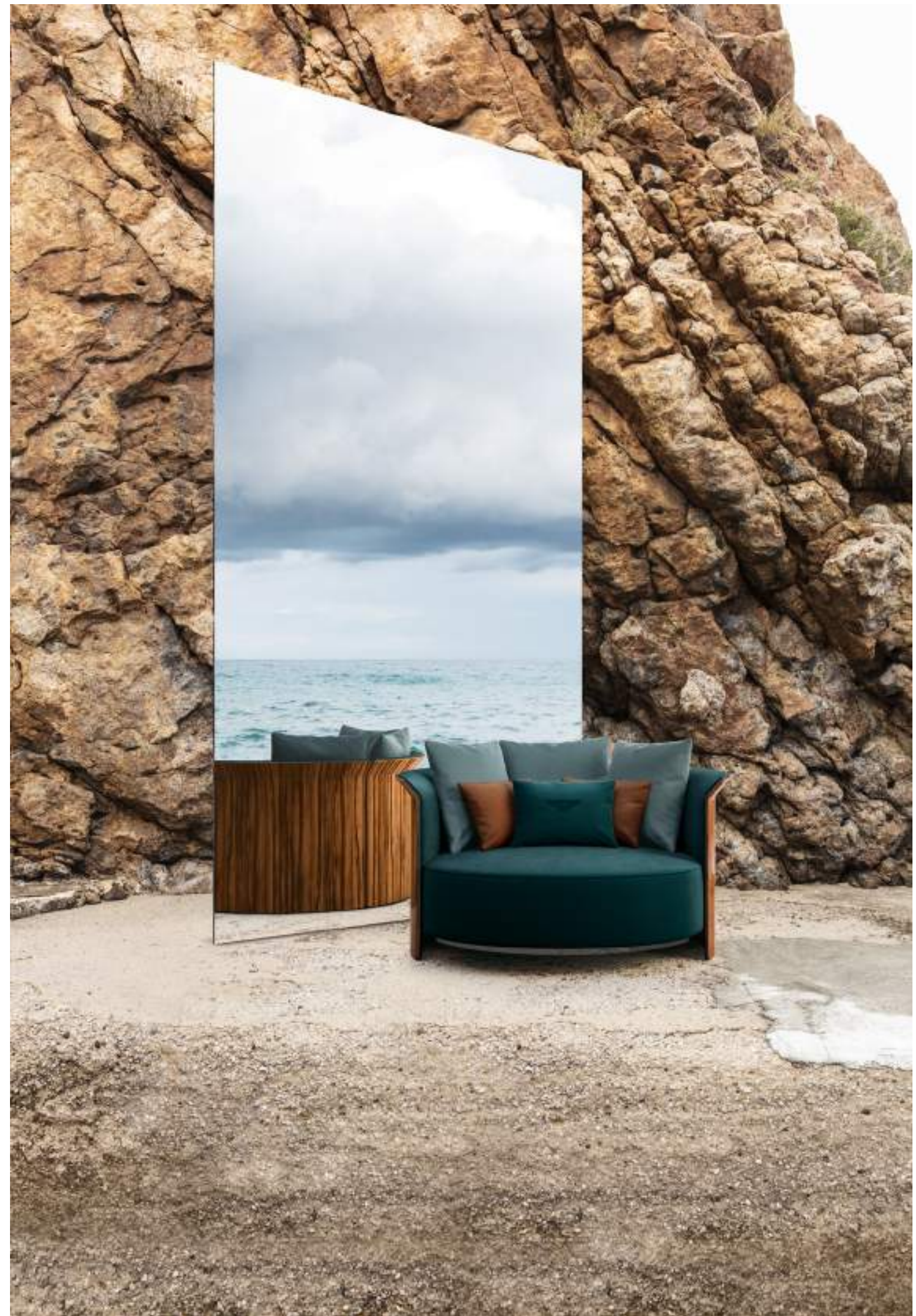



RAMSEY LOVESEAT



# FROM CEFALÙ TO PUNTA BIANCA



THE MARLSTONE CLIFFS ERODED BY WIND AND WATER,  
THE ENCHANTING COVES OF WHITE SAND WASHED  
BY THE EMERALD GREEN OF THE SEA: PUNTA BIANCA NATURE  
RESERVE IS ONE OF SICILY'S MOST SPELLBINDING BEACHES.  
A HEAVENLY LANDSCAPE, JUST A STONE'S THROW FROM  
THE VALLEY OF THE TEMPLES.





ALDFORD TABLE



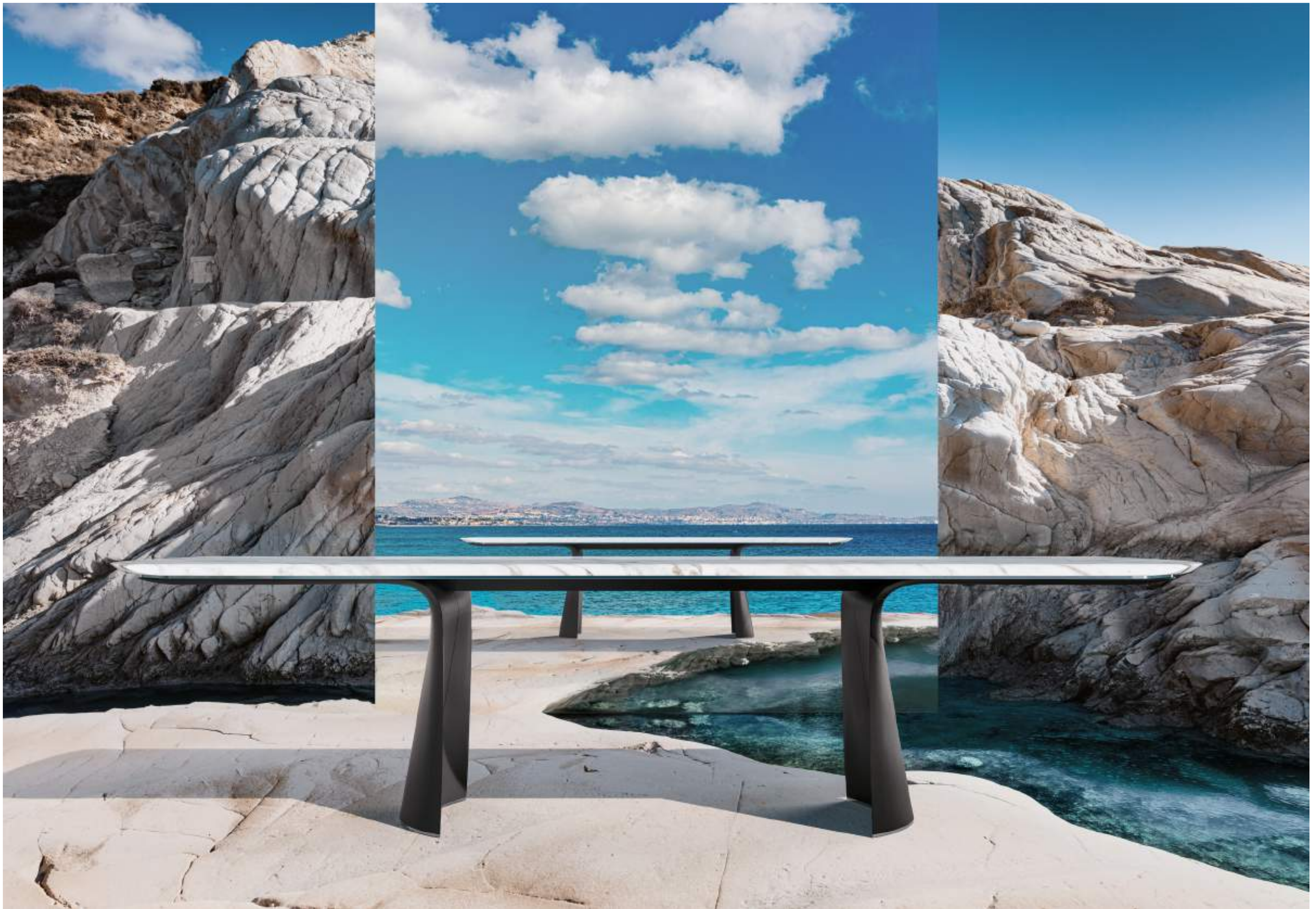



ALDFORD TABLE



RIDLEY CHAIR



RIDLEY CHAIR



HAVERGATE

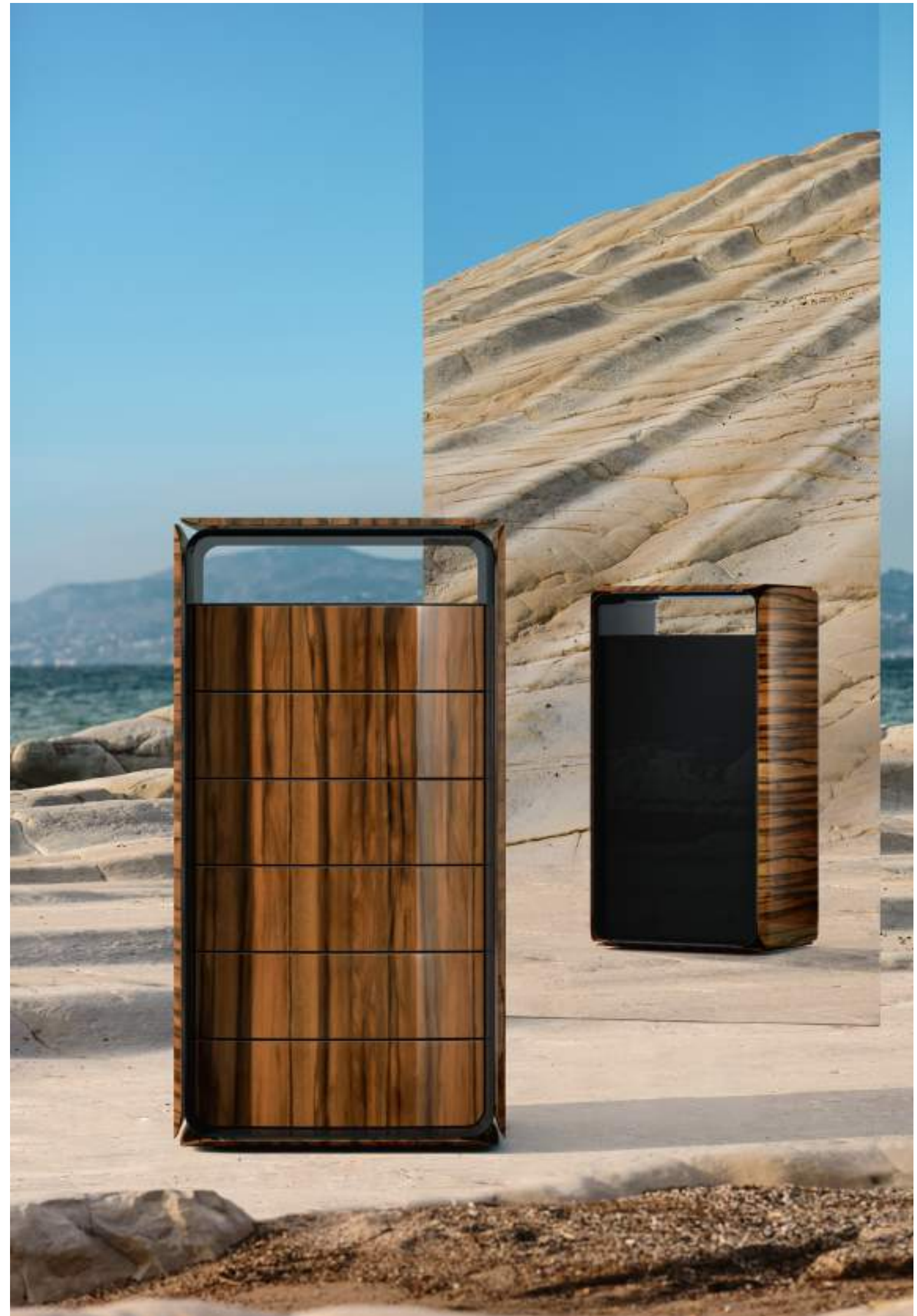









RAMSEY BED









RAMSEY BED



# FROM PUNTA BIANCA TO FAVIGNANA



THE TOPONYM FAVIGNANA DERIVES FROM THE LATIN FAVONIUS, THE NAME USED BY THE ROMANS FOR THE WARM WEST WIND. AMID LABYRINTHINE TUNNELS, ANCIENT QUARRIES AND CAVERNS ARE HIDDEN THE WONDERS OF AN INDOMITABLE, SUN-SCORCHED LAND. A GIANT, SECRET EDEN, WHERE NATURE AND HISTORY MERGE AMONG HIBISCUS PLANTS, PALM TREES AND TROPICAL FLOWERS.





RAMSEY SOFA





RAMSEY SOFA



SWAN SOFA







SWAN SOFA





RAMSEY ARMCHAIR







RAMSEY ARMCHAIR

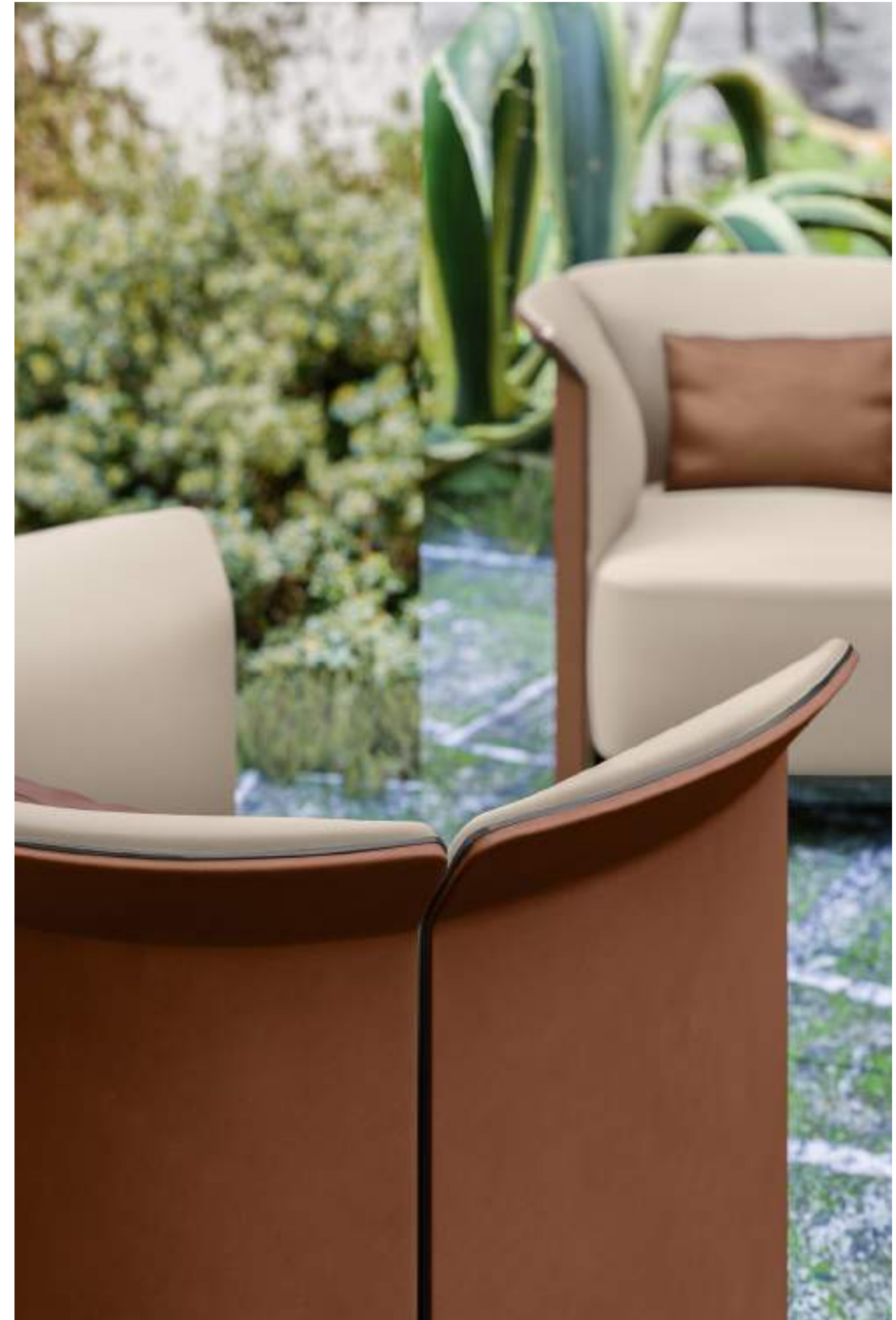

# FROM FAVIGNANA TO CUSTONACI



NORTH OF TRAPANI, NESTLED BETWEEN THE SEA  
AND THE SLOPES OF MONTE COFANO, THE QUARRIES AT  
CUSTONACI ARE A DAZZLING SIGHT. BETWEEN THE TOWERING  
WHITE WALLS, THE MARBLE EXTRACTED HERE IS AMONG THE  
FINEST IN ITALY, AND IS EXPORTED ALL OVER THE WORLD.



NEWENT BED











NEWENT BED



NEWENT SOFA









NEWENT SOFA





EASTWOOD BOOKSHELF





EASTWOOD BOOKSHELF



# TECHNICAL

Images and colours of the products printed in this catalogue are purely for information. The products shown in the pictures do not have only one standard cover. Depending on the model, products can be covered both in fabric and/or leather as from the official BENTLEY HOME collection set of samples and price-list in force during the printing of the catalogue. Drawings show the standard version of the product. All the dimensions included in technical descriptions are in cm (inch.), approximate and subject to possible changes (tolerance of +/- 2%).

Due to natural variations of the colorant dyes during the bathing and drying process of the leathers, some slight differences in shade may occur on the final product. Any eventual difference in colour that can be noticed between different panels that are joined together to create the same product, must be considered acceptable. As a result of technical/production updates, the company reserves the right to change the product information shown on this catalogue anytime and without advance notice.

## NEWENT SOFA

DESIGN BY: CARLO COLOMBO

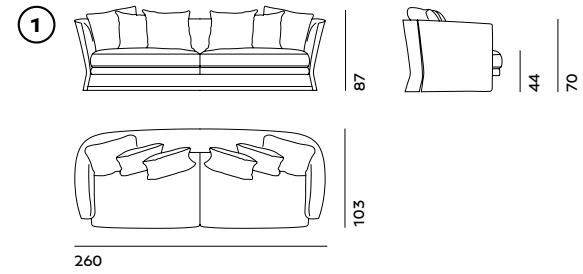

- ① 3 SEATER SOFA: NWE (D3)  
VENEERED: NWE (D3E)

L= 260 (102 1/3")  
D= 103 (40 2/3")  
H= 87 (34 1/3")  
HA= 70 (27 2/3")  
HS= 44 (17 1/4")

- ② 4 SEATER SOFA: NWE (D4)  
VENEERED: NWE (D4E)

L= 306 (120 1/3")  
D= 103 (40 2/3")  
H= 87 (34 1/3")  
HA= 70 (27 2/3")  
HS= 44 (17 1/4")

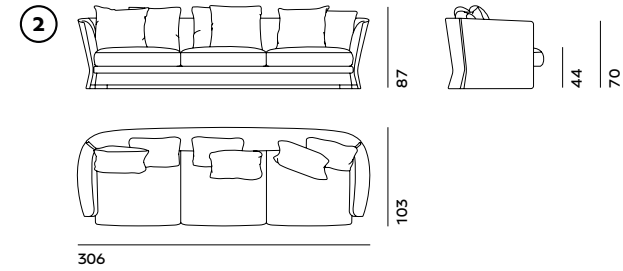

## NEWENT ARMCHAIR

DESIGN BY: CARLO COLOMBO

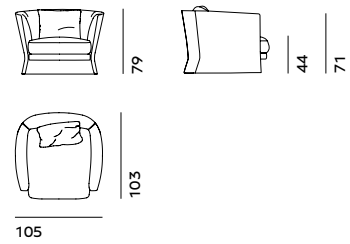

ARMCHAIR: NWE (POL)  
VENEERED: NWE (POLE)

L= 105 (41 1/3")  
D= 103 (40 2/3")  
H= 79 (31")  
HA= 71 (28")  
HS= 44 (17 1/4")

## RAMSEY SOFA

DESIGN BY: CARLO COLOMBO

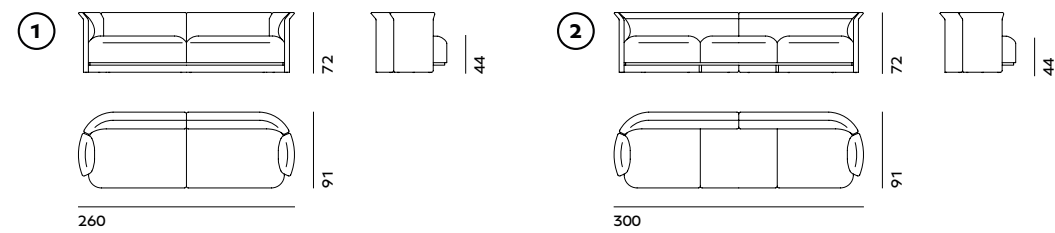

- ① 3 SEATER SOFA: FET (D3)  
VENEERED: FET (D3E) - FET (D3E/SCZ)

L= 260 (102 1/3")  
D= 91 (35 2/3")  
H= 72 (28 1/3")  
HS= 44 (17 1/4")

- ② 4 SEATER SOFA: FET (D4)  
VENEERED: FET (D4E) - FET (D4E/SCZ)

L= 300 (118")  
D= 91 (35 2/3")  
H= 72 (28 1/3")  
HS= 44 (17 1/4")

## RAMSEY ARMCHAIR

DESIGN BY: CARLO COLOMBO

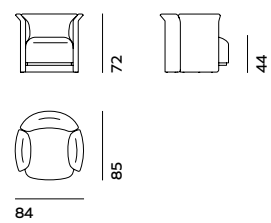

ARMCHAIR: FET (POL)  
VENEERED: FET (POLE) - FET (POLE/SCZ)

L= 84 (33")  
D= 85 (33 1/3")  
H= 72 (28 1/3")  
HS= 44 (17 1/4")

## RAMSEY LOVESEAT

DESIGN BY: CARLO COLOMBO

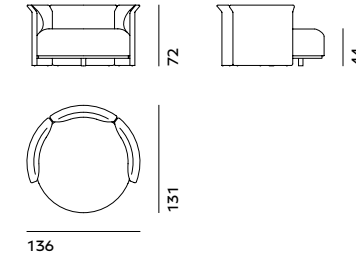

LOVESEAT: FET (LS)  
VENEERED: FET (LSE) - FET (LSE/SCZ)

L= 136 (53 2/3")  
D= 131 (51 2/3")  
H= 72 (28 1/3")  
HS= 44 (17 1/4")

## SWAN SOFA

DESIGN BY: CARLO COLOMBO

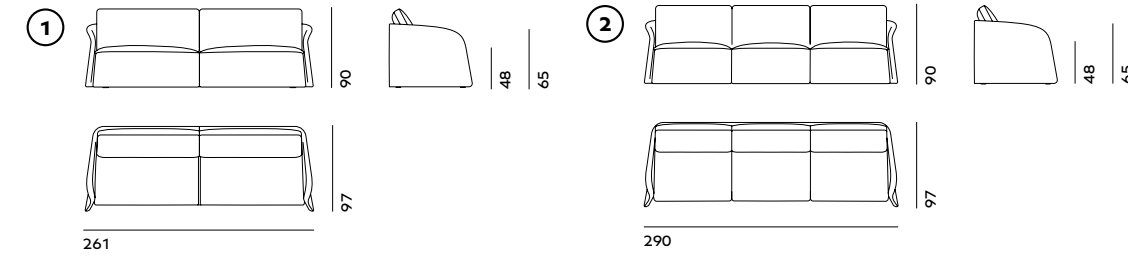

- ① 3 SEATER SOFA: 1SW (D3)

L= 261 (102 2/3")  
D= 97 (38 1/3")  
H= 90 (35 1/3")  
HA= 65 (25 2/3")  
HS= 48 (19")

- ② 4 SEATER SOFA: 1SW (D4)

L= 290 (114 1/3")  
D= 97 (38 1/3")  
H= 90 (35 1/3")  
HS= 48 (19")  
HA= 65 (25 2/3")

## SWAN ARMCHAIR

DESIGN BY: CARLO COLOMBO

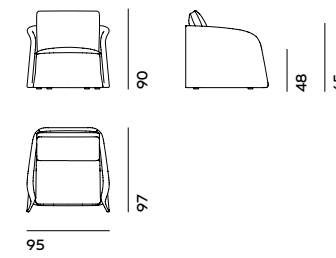

ARMCHAIR: 1SW (POL)

L= 95 (37 1/3")  
D= 97 (38 1/3")  
H= 90 (35 1/3")  
HA= 65 (25 2/3")  
HS= 48 (19")

## RAMSEY CHAIR

DESIGN BY: CARLO COLOMBO

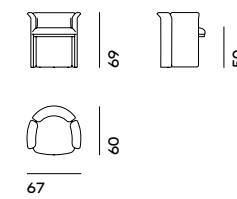

CHAIR: FET (SED)  
VENEERED: FET (SEDE) - FET (SEDE/SCZ)

L= 67 (26 1/3")  
D= 60 (23 2/3")  
H= 69 (27")  
HS= 50 (19 3/4")

## RIDLEY CHAIR

DESIGN BY: LUXURY LIVING GROUP

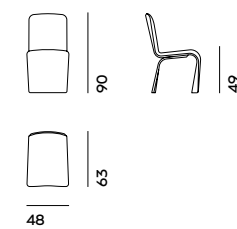

CHAIR: SDB (15P)  
SYCAMORE - LIQUIDAMBAR -  
BURR WALNUT: SDB (15E) - SDB (15E/SCZ)

L= 48 (19")  
D= 63 (24 2/3")  
H= 90 (35 1/3")  
HS= 49 (19 1/4")

ALDFORD TABLE

DESIGN BY: LUXURY LIVING GROUP

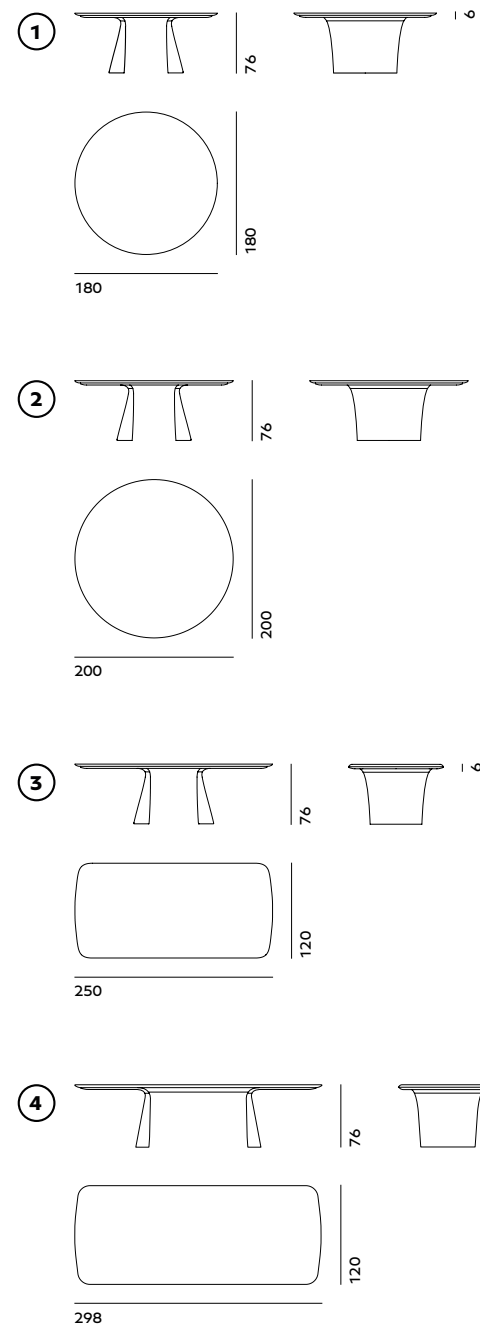

- ① VENEERED: BTV (32EE) - BTV (32EE/SCZ)  
VENEERED TOP + LEATHER LEGS:  
BTV (32EP)  
MARBLE TOP + VENEERED LEGS:  
BTV (32ME) - BTV (32ME/SCZ)  
MARBLE TOP + LEATHER LEGS:  
BTV (32MP)  
  
L-D Ø= 180 (71")  
H= 76 (30")  
THK= 6 (2 6/16")
- ② VENEERED: BTV (30EE) - BTV (30EE/SCZ)  
VENEERED TOP + LEATHER LEGS:  
BTV (30EP)  
MARBLE TOP + VENEERED LEGS:  
BTV (30ME) - BTV (30ME/SCZ)  
MARBLE TOP + LEATHER LEGS:  
BTV (30MP)  
  
L-D Ø= 200 (78 2/3")  
H= 76 (30")  
THK= 6 (2 6/16")
- ③ VENEERED: BTV (31EE) - BTV (31EE/SCZ)  
VENEERED TOP + LEATHER LEGS:  
BTV (31EP)  
MARBLE TOP + VENEERED LEGS:  
BTV (31ME) - BTV (31ME/SCZ)  
MARBLE TOP + LEATHER LEGS:  
BTV (31MP)  
  
L= 250 (98 1/3")  
D= 120 (47 1/3")  
H= 76 (30")  
THK= 6 (2 6/16")
- ④ VENEERED: BTV (29EE) - BTV (29EE/SCZ)  
VENEERED TOP + LEATHER LEGS:  
BTV (29EP)  
MARBLE TOP + VENEERED LEGS:  
BTV (29ME) - BTV (29ME/SCZ)  
MARBLE TOP + LEATHER LEGS:  
BTV (29MP)  
  
L= 298 (117 1/3")  
D= 120 (47 1/3")  
H= 76 (30")  
THK= 6 (2 6/16")

STYAL DESK

DESIGN BY: CARLO COLOMBO

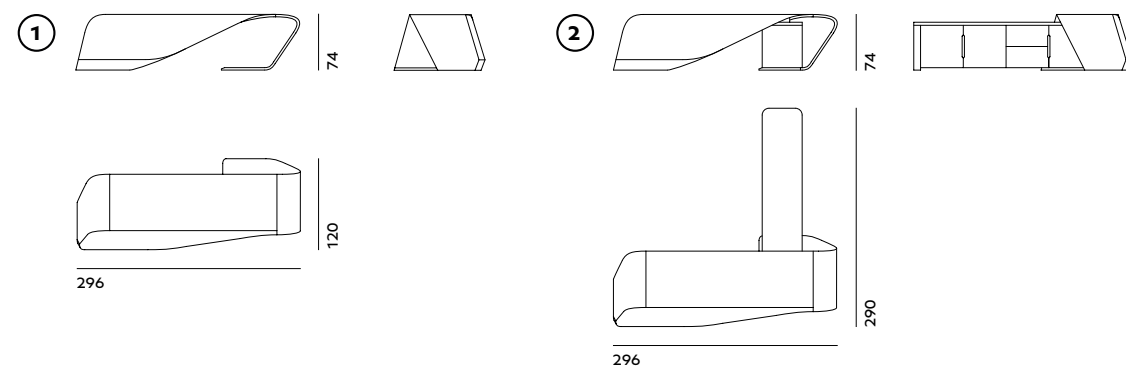

- ① VENEERED RIGHT OR LEFT  
WRITING-DESK: BTV (33E)  
LEATHER RIGHT OR LEFT  
WRITING-DESK: BTV (33P)  
SPECIAL CUSTOMIZATION - RIGHT OR LEFT  
WRITING-DESK: BTV (33/SCZ)  
  
L= 296 (116 2/3")  
D= 120 (47 1/3")  
H= 74 (29")
- ② VENEERED RIGHT OR LEFT WRITING-DESK  
+ SIDEBOARD WITH LEATHER DRAWERS:  
BTV (33EMP)  
LEATHER RIGHT OR LEFT WRITING-DESK  
+ SIDEBOARD WITH LEATHER DRAWERS:  
BTV (33PMP)  
SPECIAL CUSTOMIZATION - RIGHT OR  
LEFT WRITING-DESK WITH LEATHER  
SIDEBOARD: BTV (33MP/SCZ)  
  
L= 296 (116 2/3")  
D= 290 (114 1/3")  
H= 74 (29")

KINGSTON OFFICE ARMCHAIR

DESIGN BY: CARLO COLOMBO

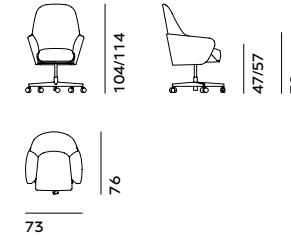

- OFFICE ARMCHAIR: POB (22)  
VENEERED: POB (22E)  
  
L= 73 (28 2/3")  
D= 76 (30")  
H= 104/114 (41"/45")  
HS= 47/57 (18 2/4" / 22 1/3")  
HA= 70 (27 2/3")

EASTWOOD BOOKSHELF

DESIGN BY: CARLO COLOMBO

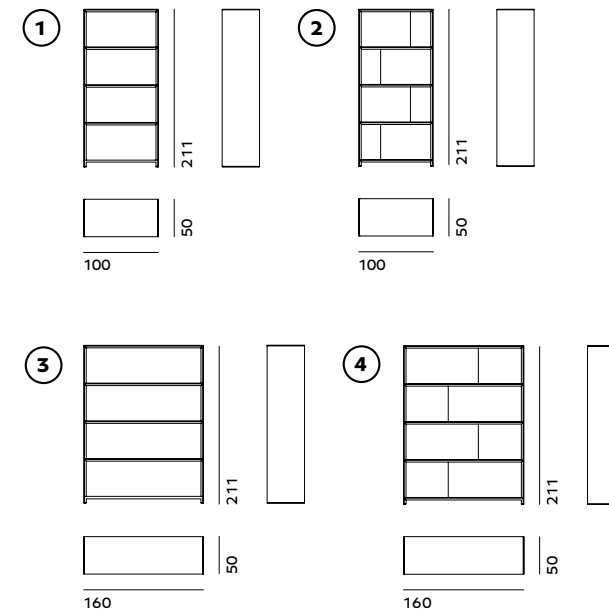

- ① BOOKSHELF: MDB (20)  
  
L= 100 (39 1/3")  
D= 50 (19 3/4")  
H= 211 (83")
- ② BOOKSHELF WITH OPTIONAL: MDB (20)  
  
L= 100 (39 1/3")  
D= 50 (19 3/4")  
H= 211 (83")
- ③ BOOKSHELF: MDB (21)  
  
L= 160 (63")  
D= 50 (19 3/4")  
H= 211 (83")
- ④ BOOKSHELF WITH OPTIONAL: MDB (21)  
  
L= 160 (63")  
D= 50 (19 3/4")  
H= 211 (83")

HAVERGATE CHEST OF DRAWERS "SETTIMINO"

DESIGN BY: LUXURY LIVING GROUP

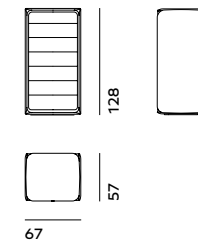

- VENEERED: BCM (22EE) - BCM (22EE/SCZ)  
WOODEN FRAME + MARBLE TOP:  
BCM (22EM) - BCM (22EM/SCZ)  
WOODEN FRAME + LEATHER TOP:  
BCM (22EP) - BCM (22EP/SCZ)  
LEATHER FRAME + LEATHER TOP:  
BMB (22PP)  
LEATHER FRAME + MARBLE TOP:  
BMB (22PM)  
  
L= 67 (26 1/3")  
D= 57 (22 1/3")  
H= 128 (50 1/3")

HAVERGATE CHEST OF DRAWERS

DESIGN BY: LUXURY LIVING GROUP

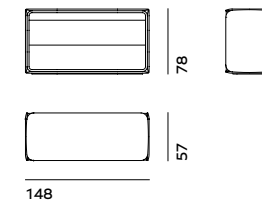

- VENEERED: BCM (21EE) - BCM (21EE/SCZ)  
WOODEN FRAME + MARBLE TOP:  
BCM (21EM) - BCM (21EM/SCZ)  
WOODEN FRAME + LEATHER TOP:  
BCM (21EP) - BCM (21EP/SCZ)  
LEATHER FRAME + LEATHER TOP:  
BMB (21PP)  
LEATHER FRAME + MARBLE TOP:  
BMB (21PM)  
  
L= 148 (58 1/3")  
D= 57 (22 1/3")  
H= 78 (30 2/3")

HAVERGATE BEDSIDE TABLE

DESIGN BY: LUXURY LIVING GROUP

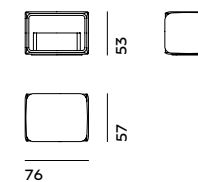

- VENEERED: BCM (9EE) - BCM (9EE/SCZ)  
WOODEN FRAME + MARBLE TOP:  
BCM (9EM) - BCM (9EM/SCZ)  
WOODEN FRAME + LEATHER TOP:  
BCM (9EP) - BCM (9EP/SCZ)  
LEATHER FRAME + LEATHER TOP:  
BCM (9PP)  
LEATHER FRAME + MARBLE TOP:  
BCM (9PM)  
  
L= 76 (30")  
D= 57 (22 1/3")  
H= 53 (21")

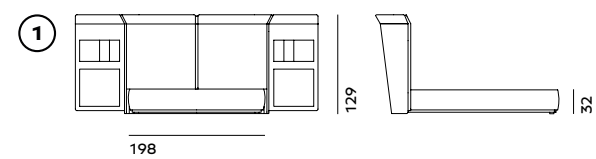

① BED: FET (LE1) + FET (SPO)  
VENEERED: FET (LE1E)  
+ FET (SPOE)  
FOR MATTRESS  
165x200 (65x78 2/3")  
  
L= 198-317 (78-124 2/3")  
D= 241 (95")  
H= 129 (50 2/3")  
HB= 32 (12 2/4")

④ BED: FET (QUSA) + FET (SPO)  
VENEERED: FET (QUSAE)  
+ FET (SPOE)  
FOR MATTRESS QUEEN USA:  
152x205 (60x80 2/3")  
  
L= 185-304 (73-119 2/3")  
D= 246 (97")  
H= 129 (50 2/3")  
HB= 32 (12 2/4")

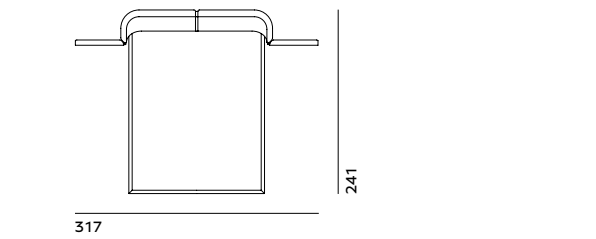

② BED: FET (LE2) + FET (SPO)  
VENEERED: FET (LE2E)  
+ FET (SPOE)  
FOR MATTRESS  
185x200 (73x78 2/3")  
  
L= 218-337 (85 2/3-132 2/3")  
D= 241 (95")  
H= 129 (50 2/3")  
HB= 32 (12 2/4")

⑤ BED: FET (KUSA) + FET (SPO)  
VENEERED: FET (KUSAE)  
+ FET (SPOE)  
FOR MATTRESS KING USA:  
195x205 (76 2/3x80 2/3")  
  
L= 228-347 (89 2/3-136 2/3")  
D= 246 (97")  
H= 129 (50 2/3")  
HB= 32 (12 2/4")

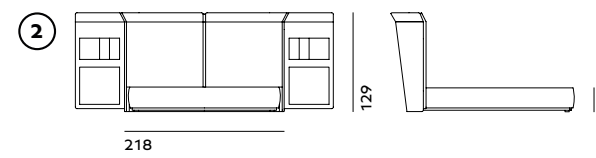

③ BED: FET (LE7) + FET (SPO)  
VENEERED: FET (LE7E)  
+ FET (SPOE)  
FOR MATTRESS  
200x200 (78 2/3x78 2/3")  
  
L= 233-352 (91 2/3-138 1/2")  
D= 241 (95")  
H= 129 (50 2/3")  
HB= 32 (12 2/4")

⑥ BED: FET (CUSA) + FET (SPO)  
VENEERED: FET (CUSAE)  
+ FET (SPOE)  
FOR MATTRESS CALIFORNIA USA:  
183x215 (72x84 2/3")  
  
L= 218-337 (85 2/3-132 2/3")  
D= 256 (100 2/3")  
H= 129 (50 2/3")  
HB= 32 (12 2/4")

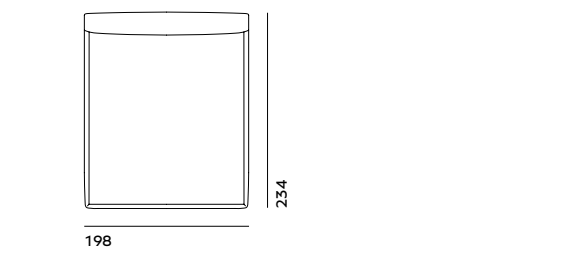
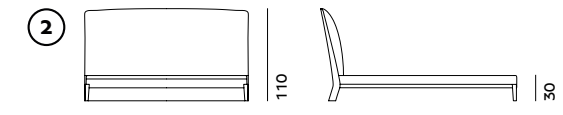
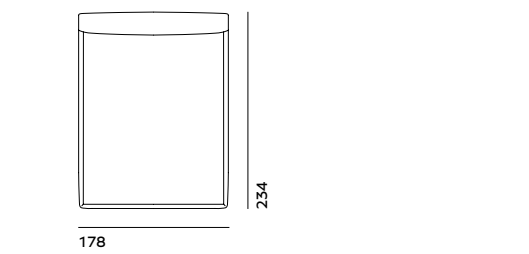
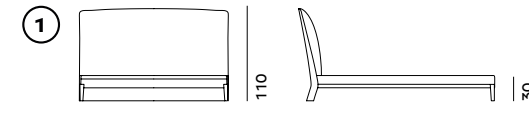
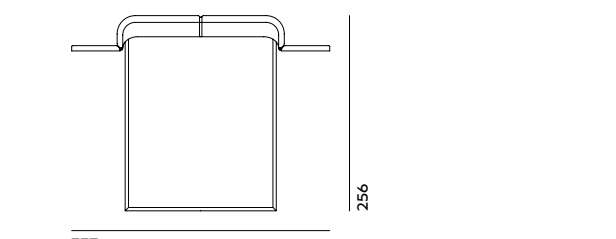
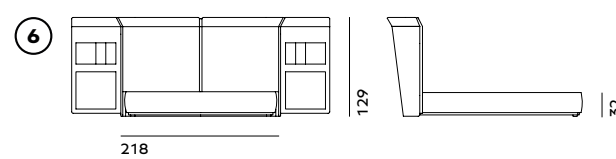
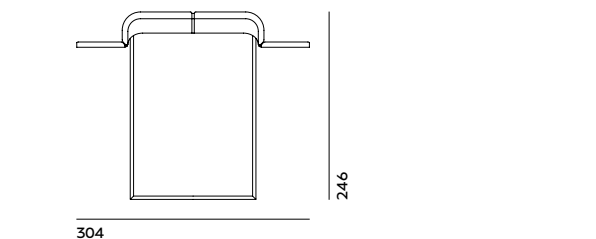
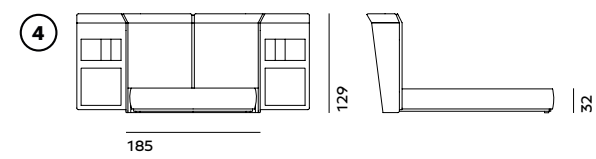
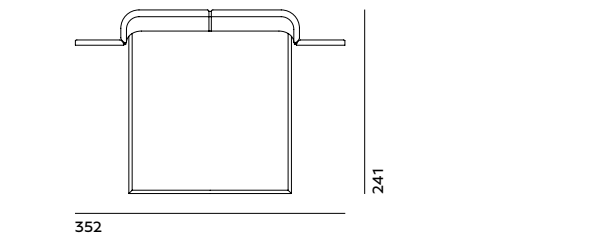
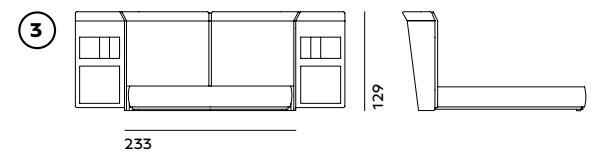
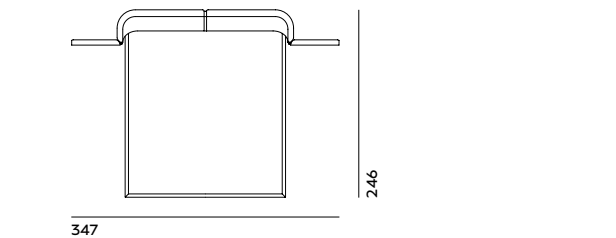
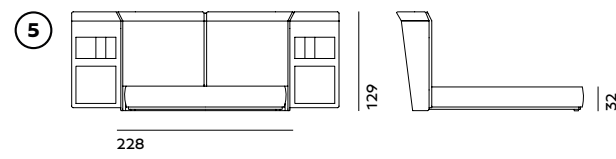
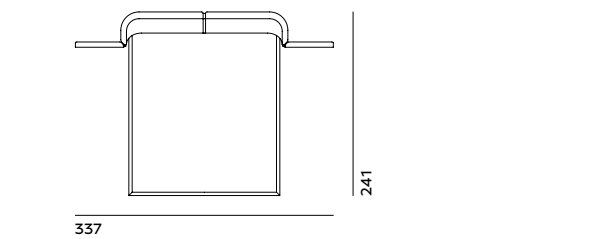

① BED: NWE (LE1)  
VENEERED: NWE (ELE1)  
FOR MATTRESS 165x200 (65x78 2/3")  
  
L= 178 (70")  
D= 234 (92")  
H= 110 (43 1/3")  
HB= 30 (11 3/4")

② BED: NWE (LE2)  
VENEERED: NWE (ELE2)  
FOR MATTRESS 185x200 (73x78 2/3")  
  
L= 198 (78")  
D= 234 (92")  
H= 110 (43 1/3")  
HB= 30 (11 3/4")

③ BED: NWE (LE7)  
VENEERED: NWE (ELE7)  
FOR MATTRESS 200x200 (78 2/3x78 2/3")  
  
L= 213 (84")  
D= 234 (92")  
H= 110 (43 1/3")  
HB= 30 (11 3/4")

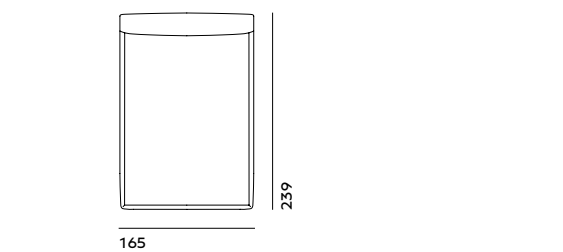
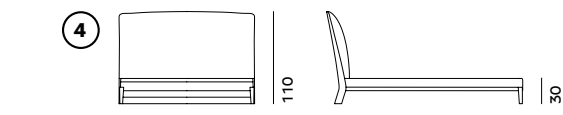
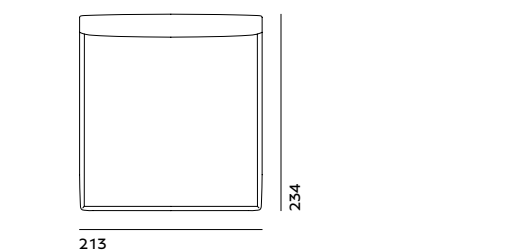
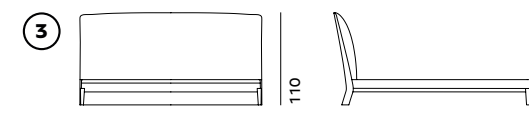

④ BED: NWE (QUSA)  
VENEERED: NWE (EQUSA)  
FOR MATTRESS QUEEN USA  
152x205 (60x80 2/3")  
  
L= 165 (65")  
D= 239 (94")  
H= 110 (43 1/3")  
HB= 30 (11 3/4")

⑤ BED: NWE (KUSA)  
VENEERED: NWE (EKUSA)  
FOR MATTRESS KING USA  
195x205 (76 2/3x80 2/3")  
  
L= 208 (82")  
D= 239 (94")  
H= 110 (43 1/3")  
HB= 30 (11 3/4")

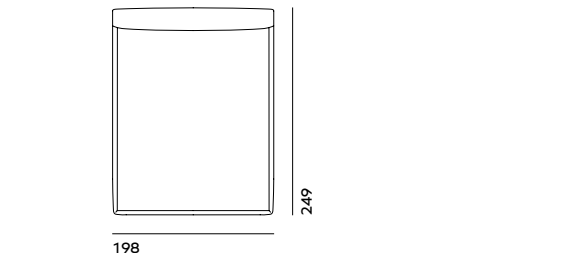
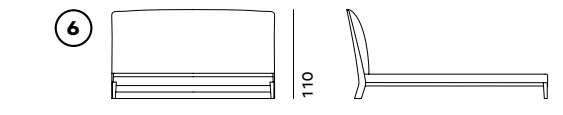
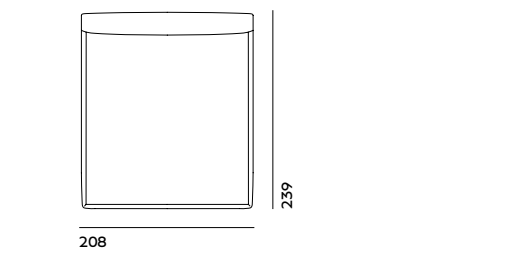
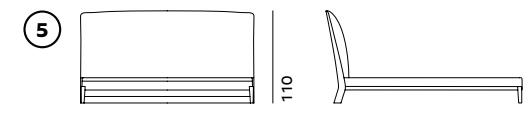

⑥ BED: NWE (CUSA)  
VENEERED: NWE (ECUSA)  
FOR MATTRESS CALIFORNIA USA  
183x215 (72x84 2/3")  
  
L= 198 (78")  
D= 249 (98")  
H= 110 (43 1/3")  
HB= 30 (11 3/4")

# BACKSTAGE











